

**Gamesa
G58-850 kW**



Benefits

Optimum performance for low winds

- ▶▶ Class IIA/IIIB.
- ▶▶ Pitch and variable speed technology to maximize energy production.
- ▶▶ Production of lighter blades using fiberglass and prepreg method.
- ▶▶ Compliance with the main international Grid Codes.
- ▶▶ Aerodynamic design and Gamesa NRS® control system to minimize noise emissions.
- ▶▶ Gamesa WindNet®: Remote monitoring and control system with Web access.
- ▶▶ Over 7,700 Gamesa G5X-850 kW wind turbines installed.



G58-850 kW

Rotor

Diameter	58 m
Swept area	2,642 m ²
Rotational speed	Variable 14.6 - 30.8 rpm, tower 55 and 65m Variable 16.2 - 30.8 rpm, tower 44m
Rotational direction	Clock Wise (front view)
Weight (incl. Hub)	Approx. 12 T
Top head mass	Approx. 35 T

Blades

Number of blades	3
Length	28.3 m
Airfoils	NACA 63.XXX + FFA-W3
Material	Epoxy reinforced glass fiber
Total blade weight	2,400 kg

Tubular Tower

Modular type	Height	Weight
2 sections	44 m	45 T
3 sections	55 m	62 T
3 sections	65 m	79 T

Gearbox

Type	1 planetary stage / 2 helical stages
Ratio	1:61.74 (50 Hz) 1:74,5 (60 Hz)
Cooling	Oil pump with oil cooler
Oil heater	1.5 kW

Generator 850 kW

Type	Doubly-fed machine
Rated power	850 kW
Voltage	690 V ac
Frequency	50 Hz / 60 Hz
Protection class	IP 54
Number of poles	4
Rotational speed	1,000:1,950 rpm (50 Hz) 1,320:2,340 rpm (60 Hz)
Rated Stator Current	670 A @ 690 V
Power factor (standard)	0.95 CAP - 0.95 IND at partial loads and 1 at nominal power.*
Power factor (optional)	0.95 CAP - 0.95 IND throughout the power range.*

* Power factor at generator output terminals, on low voltage side before transformer input terminals.

Mechanical design

Drive train with main shaft supported by two spherical bearings that transmit the side loads directly to the frame by means of the bearing housing. This prevents the gearbox from receiving additional loads, reducing malfunctions and facilitating its service.

Brake

Aerodynamic primary brake by means of full-feathering blades. In addition, a hydraulically-activated mechanical disc brake for emergencies is mounted on the gearbox high speed shaft.

Lightning protection

The Gamesa G58-850 kW wind turbine generator uses the "total lightning protection" system, in accordance with standard IEC 61024-1. This system conducts the lightning from both sides of the blade tip down to the root joint and from there across the nacelle and tower structure to the grounding system located in the foundations. As a result, the blade and sensitive electrical components are protected from damage.

Control System

The Generator is a doubly fed machine (DFM), whose speed and power is controlled through IGBT converters and PWM (Pulse Width Modulation) electronic control.

Benefits:

- ▶▶ Active and reactive power control.
- ▶▶ Low harmonic content and minimal losses.
- ▶▶ Increased efficiency and production.
- ▶▶ Prolonged working life of the turbine.

Gamesa WindNet[®]

The new generation SCADA System (a wind farm control system) entirely developed by Gamesa allows realtime operation and remote control of wind turbines, meteorological mast and the electrical substation. This innovative modular design based on TCP/IP architecture has tools for controlling active and reactive energy, voltage and frequency. It also contains environmental options to optimize the production to perfectly comply with regulations currently in force. The intuitive remote web client employs a very friendly user interface. The system includes analytical tools for decision-making, Report Generator and Information Manager and TrendViewer, to give a sharp, clear view of trends.

SMP Predictive Maintenance System

Predictive Maintenance System for the early detection of potential deterioration or malfunctions in the wind turbine's main components.

Benefits:

- ▶▶ Reduction in major corrective measures.
- ▶▶ Increase in the machine's availability and working life.
- ▶▶ Preferential terms in negotiations with insurance companies.
- ▶▶ Integration within the control system.

Noise control

Aerodynamic blade tip and mechanical component design minimize noise emissions. In addition, Gamesa has developed the Gamesa NRS® noise control system, which permits programming the noise emissions according to criteria such as date, time or wind direction. This achieves the goals of local regulation compliance as well as maximum production.

Grid connection

Gamesa's doubly-fed wind turbines and Active Crowbar and over sized converter technologies ensure compliance with the most demanding grid connection requirements. Low voltage ride-through capability and dynamic regulation of active and reactive power.



- 1 Service crane
- 2 Generator
- 3 Cooling system
- 4 Top control unit
- 5 Gearbox
- 6 Main shaft with two bearings
- 7 Rotor lock system
- 8 Blade
- 9 Blade Hub
- 10 Hub cover
- 11 Blade bearing
- 12 Bed frame
- 13 Hydraulic unit
- 14 Shock absorbers
- 15 Yaw ring
- 16 Brake
- 17 Tower
- 18 Yaw gears
- 19 Transmission. High speed shaft

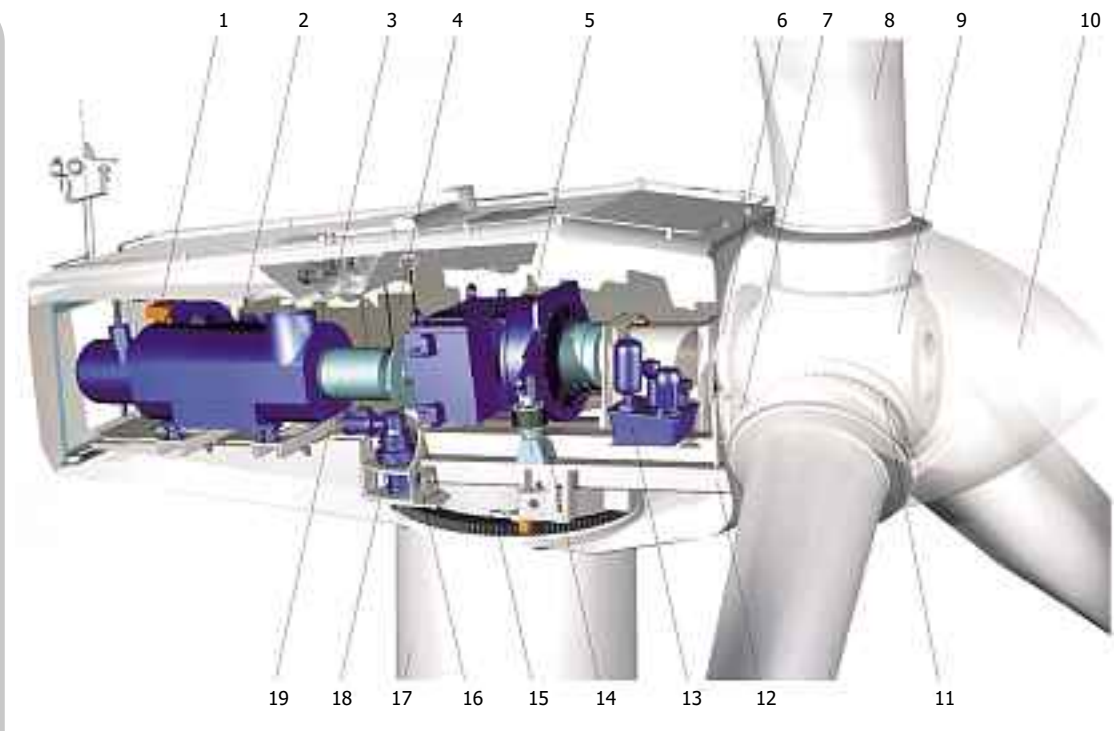

Power Curve Gamesa G58-850kW

(for an air density of 1.225 kg/m³)

Power curve calculation based on NACA 63.XXX and FFA-W3 airfoils.

Calculation parameters: 50 Hz grid frequency; tip angle pitch regulated, 10% turbulence intensity and a variable rotor speed ranging from 14.6 - 30.8 rpm.

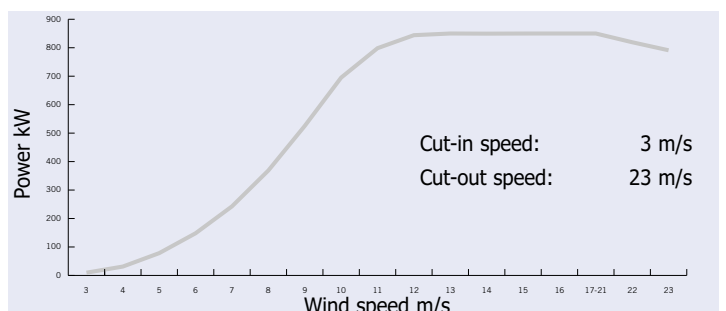

C/ Ciudad de la Innovación, 9-11
31621 Sarriguren (Spain)
Tel: +34 948 771000
Fax: +34 948 165039
info@gamesacorp.com
www.gamesacorp.com

CHINA

Room 605,
CBD International Building
N.º 16, Yong An Dong Li,
Chaoyang District
Beijing 100022
Tel.: +86 10 6567 9888
Fax: +86 10 6566 9666

DENMARK

Vejlsøvej 51
8600 Silkeborg
Tel: +45 87 229205 / 9204
Fax: +45 87 229201

EGYPT

12 Dar el Shefa Street 3th. Floor,
Garden City- Cairo
Tel: +20 166642424
Fax: +20 227951866

FRANCE

118-122 Avenue de France
75013 Paris
Tel: +33 1 46461423

GERMANY

Wailandtstrasse 7
63741 Aschaffenburg
Tel: +49 (0) 6021 15 09 0
Fax: +49 (0) 6021 15 09 199
germany.wind@gamesacorp.com

INDIA

N.º 489, GNT Road, Thandal Kazhani Village
Vadagarai Post, Redhills, Chennai-600 052
Tel: +91 44 3098 9898
sales.india@gamesacorp.com

ITALY

Via Mentore Maggini 48/50
00143 Rome
Tel: +39 0645543650
Fax: +39 0645553974

JAPAN

Daiwa Jisho Building 4F – 411
74-1 Naka-ku,
Yamashita-cho
Yokohama-city 231-0023
Kanagawa
Tel: +81 45 680 50 80
Fax: +81 45 680 50 81

MOROCCO

345, Lot Gzennaya A B.P 397
Tangier (Boukhalef)
Tel: +212 539 393308/09
Fax: +212 539 393312

POLAND

Gdansk
Tel: +48 602 692 792

UNITED STATES

2050 Cabot Boulevard West
Langhorne, PA 19047
Tel: +1 215 710 3100
Fax: +1 215 741 4048

In order to minimize the environmental impact, this document has been printed on paper made from 50% pure cellulose fiber (ECF), 40% selected pre-consumer recycled fiber, and 10% post-consumer deinked recycled fiber inks based exclusively on vegetable oils with a minimum volatile organic compound (VOC) content. Varnish based predominantly on natural and renewable raw materials.

The present document, its content, its annexes and/or amendments has been drawn up by Gamesa Corporación Tecnológica, S.A. for information purposes only and could be modified without prior notice. All the content of the Document is protected by intellectual and industrial property rights owned by Gamesa Corporación Tecnológica, S.A. The addressee shall not reproduce any of the information, neither totally nor partially.

Printed date: March 2010

